

ACME Hex Nut

Thread Type: Acme

Thread Direction: Right Hand

Material: Carbon Steel

Class Grade: High Tensile Grade 5

Finish: Plain Black Uncoated

Corrosion Protection Level: Poor

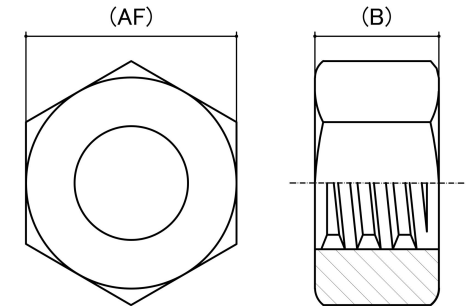

*CAD drawings shown for graphic representation only.**

Size	Thread Pitch (TPI)	Thread Type	Overall Nut Height (B) (mm)		Across Flats (AF) (mm)		Spanner Size (AF) (inches)	sku (qfind)
			Min	Max	Min	Max		
1/2"	6	Acme	10.11	11.33	20.32	20.83	7/8	41A12P
5/8"	6	Acme	14.03	14.28	25.02	25.66	1	41A58P
3/4"	6	Acme	17.50	18.00	31.38	32.00	1-1/4	41A34P
7/8"	6	Acme	18.75	19.25	34.38	35.00	1-3/8	41A78P
1"	6	Acme	21.11	22.53	36.25	36.58	1-1/2	41A1P
1-1/8"	6	Acme	23.90	25.40	41.40	42.90	1-11/16	41A118P
1-1/4"	6	Acme	26.20	27.80	46.11	47.25	1-7/8	41A114P

Disclaimer:

Dimensional data and technical information was obtained from publically available sources and not acquired through standard agencies. It has been completed and compiled for reference purposes only; where discrepancies are found they are subject to change without notice. Bolt & Nut Australia makes no warranties or representations regarding the accuracy and validity of the compiled information and data. Contact the relevant standard authorities for accurate and detailed information.

* CAD drawings may not reflect diameter, thread length or overall length.

© Bolt & Nut Australia Pty Ltd. All rights reserved.

Version: 18 Mar 2024